

## **Waste Compactors**

Reduce waste volume quickly, simply and cost effectively

## How IMC Compactors Work

### Waste Control Made Simple

IMC waste compactors will cut your waste volumes by up to 80%.

Designed to compress all dry waste, including cardboard, tins, plastic and paper, our range of compactors are tough, reliable and simple to use. Just as importantly, they'll give you a fast return on your investment, help you to improve hygiene standards and minimise the area needed for waste storage.

The IMC waste compactor range has been developed to meet the needs of almost every application, from small hotels and restaurants to large schools, hospitals, shops, factories and ships.

Each unit is manufactured from stainless steel, making it quick and easy to clean. They incorporate proven electro-hydraulic technology to ensure that waste is compacted in seconds. The compactor range is quiet, safe and energy efficient in operation, running from a normal 13 amp plug.

### Easy And Safe To Use

Our units are compact, easy to use and mounted on heavy duty casters or deck feet, so they can be located wherever waste is produced.

Waste is simply fed via a loading chute into an integral trolley, lined with a tough, sealable plastic bag, or in the larger model fed directly into standard 240 litre wheeled bins. Once the trolley or bin is full the loading door is closed, safety interlocks automatically engaged and the start button pressed. A powerful hydraulic press then compresses the waste in seconds, allowing more to be added until a 'bag full' light illuminates. For more resilient waste the constant pressure setting can be used.

The trolley or bin can then be safely removed, wheeled to the disposal point and emptied without the need for heavy lifting. The use of additional bins means that a single compactor can be used for larger kitchens or colour coded bins for easy waste segregation.

*It's as quick and simple as that!*

For larger establishments we also offer a weatherproof compactor for 1100 litre eurobins.

## IP400

The IP400 is designed to be used in smaller businesses, where waste volumes are typically lower. Tough, robust and reliable, the IP400 is supplied with an integral trolley and can produce a compacted bag weight of up to 18Kg or approximately 55 litres.



### IP400

Average compacted bag weight	16-18kg
Average compacted package	375mm x 375mm x 380mm 55 litre
Compaction force	3000kgf
Compaction ratio	5:1
Cycle time	14 seconds (including 4 second delay at bottom of stroke)
Motor	0.75kW (1HP)
Fuse rating	1 phase (13A)
Operator controls/Indicators	On/Off key ensures authorised operation Stop and start buttons Normal/constant operating mode switch Machine run indicator light Bag full indicator light
Operator safety	Interlock on trolley bin Interlock on waste-in chute
Special features	Constant pressure setting (night position) Wheeled trolley bin for easy movement 100 plastic bags, wire ties and tying tool Stainless steel trolley liners for bag rigidity
Customer options	Additional trolleys Lift-A-Pak Deck Feet for marine installations

## Dimensions IP1100

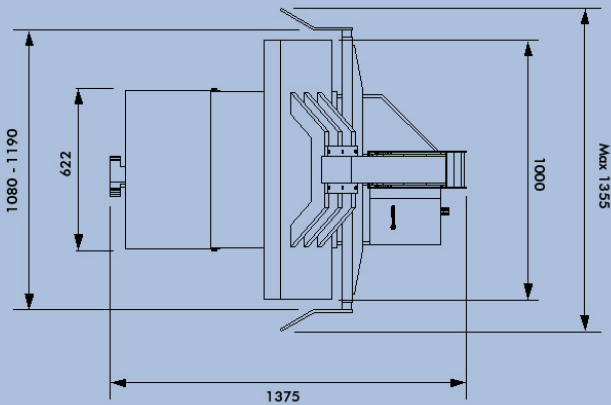
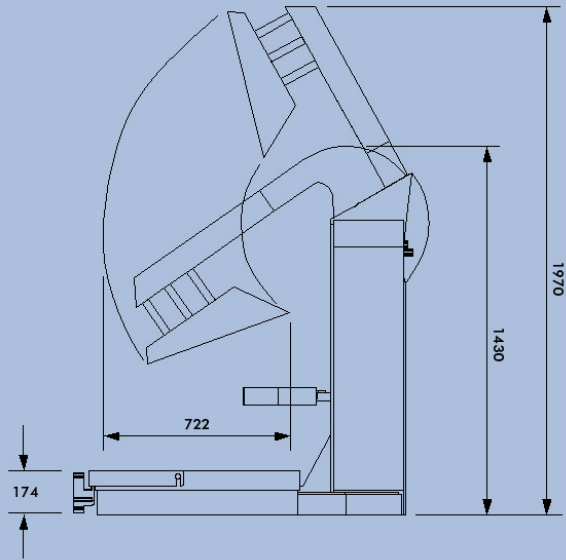

### IP1100

Average compacted package	1100 litre wheeled eurobin (not supplied)
Compaction force	3000kgf
Compaction ratio	5:1
Motor	1.5kW (2HP)
Fuse rating	1 phase (13A or 16A) 3 phase (24A or 32A)
Operator controls/ Indicators	Key switch to prevent unauthorized use Motor start button Up and down buttons to raise and lower press plate Foot pedal to operate the container support Centering mechanism
Operator safety	Lock to prevent unauthorized use
Special features	5 year warranty Weatherproof suitable for outside installation Rubber feet for stability

## Dimensions IP400, 500, 600

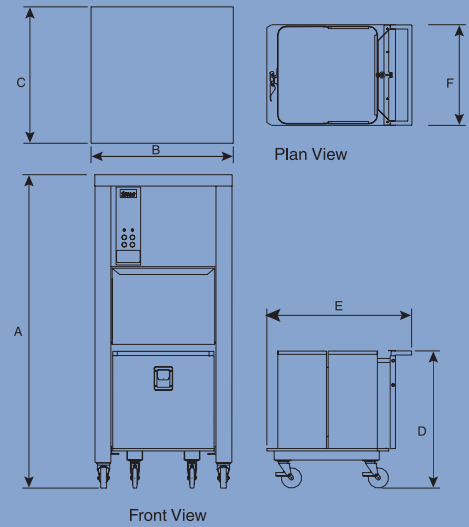

Model	A	B	C	D	E	F
IP400	1645	600	580	600	530	410
IP500	1740	678	675	730	765	520
IP600	1930	870	840	845	885	620

## Dimensions IP700

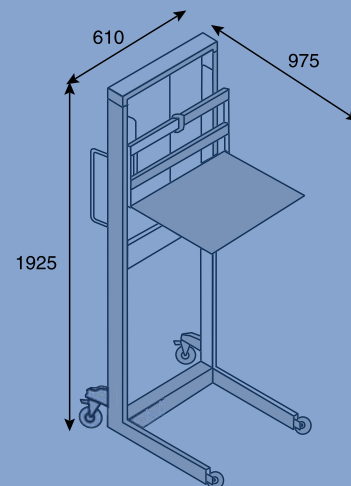
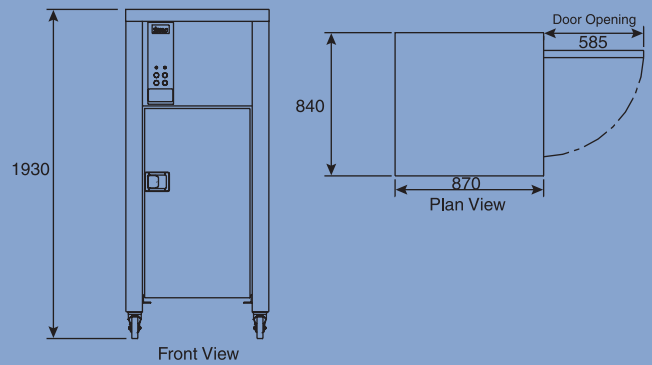

The optional Lift-A-Pak allows compacted bags to be easily lifted into a storage skip, to avoid operators lifting heavy bags.

## IP1100

The weatherproof IP1100 is designed for large commercial or institutional establishments and allows waste to be compacted by up to 80% directly into a standard wheeled plastic or metal 1100 litre Eurobin, reducing the number required by an organisation. With robust stainless steel construction and quiet operation, the system can be sited outside and has a comprehensive five year warranty.



## IP500

Ideal for larger waste volumes, the IP500 typically produces compacted bags between 25 and 30Kg in weight, of up to 110 litres. In common with the IP400 and IP600, the unit is easy to use and clean, and incorporates safety interlocks on the chute and trolley to protect both the machine and operator.



### IP500

Average compacted bag weight	25-30kg
Average compacted package	500mm x 500mm x 430mm 110 litre
Compaction force	4500kgf
Compaciton ratio	5:1
Cycle time	23 seconds (including 4 second delay at bottom of stroke)
Motor	0.75kW (1HP)
Fuse rating	1 phase (13A)
Operator controls/ Indicators	On/Off key ensures authorised operation Stop and start buttons Normal/constant operating mode switch Machine run indicator light Bag full indicator light
Operator safety	Interlock on trolley bin Interlock on waste-in chute
Special features	Constant pressure setting (night position) Wheeled trolley bin for easy movement 100 plastic bags, wire ties and tying tool Stainless steel trolley liners for bag rigidity
Customer options	Additional trolleys Lift-A-Pak Deck Feet for marine installations

## IP600

Designed for larger businesses that regularly generate higher volumes of waste, the IP600 has a compaction force of 5000kgf, producing compacted bag weights of 40kg and up to 210 litres in volume. The large, heavy duty integral trolley is easy to move and empty, with waste being compacted into sealable plastic bags.



## IP600

Average compacted bag weight	40-45kg
Average compacted package	600mm x 600mm x 580mm 210 litre
Compaction force	5000kgf
Compaction ratio	5:1
Cycle time	23 seconds (including 4 second delay at bottom of stroke)
Motor	0.75kW (1HP)
Fuse rating	1 phase (13A)
Operator controls/ Indicators	On/Off key ensures authorised operation Stop and start buttons Normal/constant operating mode switch Machine run indicator light Bag full indicator light
Operator safety	Interlock on trolley bin Interlock on waste-in chute
Special features	Constant pressure setting (night position) Wheeled trolley bin for easy movement 100 plastic bags, wire ties and tying tool Stainless steel trolley liners for bag rigidity
Customer options	Additional trolleys Lift-A-Pak Deck Feet for marine installations

## IP700

The IP700 eliminates the need for separate plastic bags by enabling standard 240 litre wheeled bins to be filled and positioned safely under the compaction head. Different colour bins can be used as part of a waste segregation or recycling scheme, while the use of safety interlocks on the door and wheeled bin ensure complete operator safety.



### IP700

Average compacted bag weight	40-45kg
Average compacted package	240 litre wheeled bin (not supplied)
Compaction force	1000kgf
Compaction ratio	5:1
Cycle time	17 seconds (including 4 second delay at bottom of stroke)
Motor	0.75kW (1HP)
Fuse rating	1 phase (13A)
Operator controls/Indicators	On/Off key ensures authorised operation Stop and start buttons Normal/constant operating mode switch Machine run indicator light Bin full indicator light
Operator safety	Interlock on door Interlock on wheeled bin
Special features	Constant pressure setting (night position) Adjustable floor plate for stability
Customer options	Deck Feet for marine installations

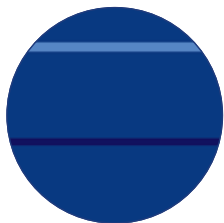

Also available is our range of food waste disposers, dewaterers and cleaning and rinsing equipment. To find out more please contact our sales team.

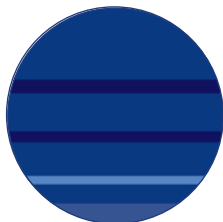

IMC was founded in 1906 and has since established itself as a leading manufacturer of catering and bar equipment, with a reputation for quality, innovation and unrivalled customer service.

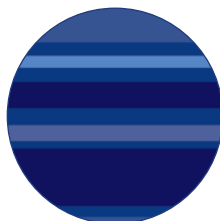

We have the resources, manufacturing expertise, knowledge and skills to provide you with complete waste management and catering solutions all of which are designed and manufactured to meet BS EN ISO9001:2000.

### The Green Machine Industrial

P.O. Box 108  
3600 AC Maarssen  
The Netherlands

Tel: +31 (0)6 53 192 745  
[www.thegreenmachine.nl](http://www.thegreenmachine.nl)  
[info@thegreenmachine.nl](mailto:info@thegreenmachine.nl)

