

THE GREEN MACHINE

I N D U S T R I A L

**Drg.
No.**

**COMMERCIAL
INST DATA 1**

COMMERCIAL FOOD WASTE DISPOSER SM75

CE tested:	Authorised:	Date:
1	K.Bonfield	02/01/21
2		
3		
4		

TGMI SM75

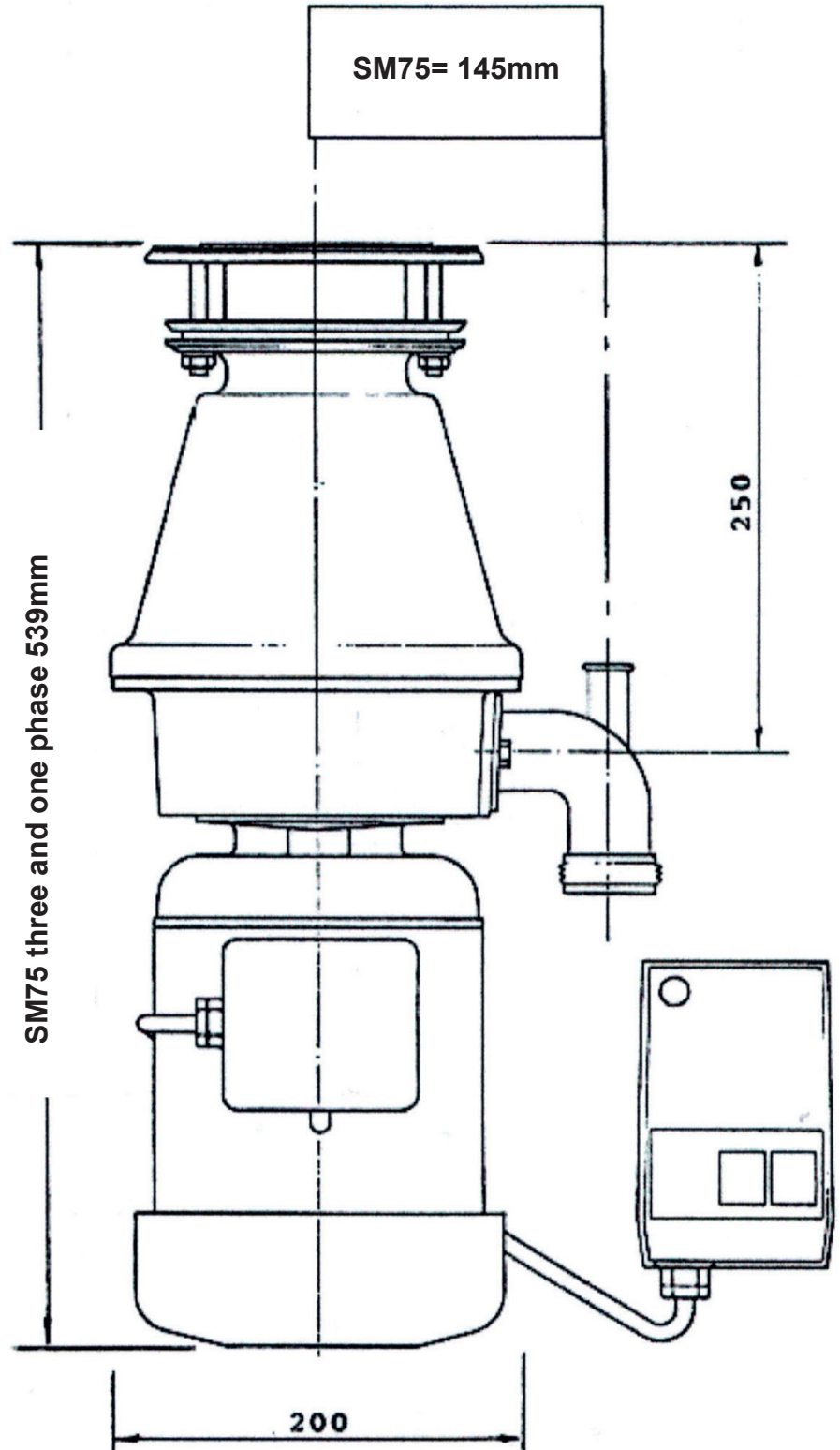

Capacity/hour 200 kg
 Motor 0.75 kW $\frac{3}{4}$ HP
 Voltage 220/240-1-50/60 or 415/440-3-50/60
 Controller Wall Mounted
 Marpol / CE Approved