



**700/800 SERIES
FOOD WASTE DISPOSERS**

MAINTENANCE MANUAL

PLEASE LEAVE WITH OPERATOR



723 1PH SERIES 1	725 1PH SERIES 4	726 1PH SERIES 4	800 1PH SERIES 3
723 3PH SERIES 3	725 3PH SERIES 6	726 3PH SERIES 6	800 3PH SERIES 3

**IMC Mainland Agent:
The Green Machine Ind.
Tel. +31 (0) 653192745
info@thegreenmachine.nl
www.thegreenmachine.nl**

700/800 Series Food Waste Disposer

EC DECLARATION OF CONFORMITY

(Guarantee of Production Quality)



We, Imperial Machine Company Limited of:
Unit 1, Abbey Road, Wrexham Industrial Estate, Wrexham, LL13 9RF
Declare under our sole responsibility that the machines:

723 1PH SERIES 1 3PH SERIES 3
725 1PH SERIES 4 3PH SERIES 6
726 1PH SERIES 4 3PH SERIES 6
800 1PH SERIES 3 3PH SERIES 3

As described in the attached technical documentation is in conformity with the Machine Safety Directive 89/392/EEC as amended by 91/368/EEC and 93/44/EEC and is manufactured under a quality system BS EN ISO 9001. It is also in conformity with the protection requirements of the Electro Magnetic Compatibility Directive 89/336/EEC and is manufactured in accordance with harmonised standards EN 55014-1 Generic Emission and EN 55014-2 Generic Immunity (plus product specific standards).

It also satisfies the essential requirements of the Low Voltage Directive 73/23/EEC amended by 93/68/EEC and is manufactured in accordance with standards BS EN 60335-1 and BS EN 60335-16.

A handwritten signature in cursive script, appearing to read 'E Plumb'.

Approved by E Plumb, Engineering Manager

Signed at Wrexham, Date

May 2016

INDEX

INDEX	3
GUARANTEE	1
WASTE OUTLET CONNECTION	1
WATER SUPPLY CONNECTION	2
ELECTRICAL CONNECTION	2
RELEASING A JAM	3
FAULT DIAGNOSIS	4
Machine does not start	4
Unexpected system stop	4
Waste not processed	4
MAINTENANCE	5
ORDERING SPARE PARTS:	5
MATERIAL CONTENT	5
WIRING DIAGRAMS	6
PARTS ILLUSTRATION,	9
723	9
725, 726, 800 Series and Dump Station	10
PARTS LIST	11
723	11
725 & 726 Series	12
800 Series and Dump Station	13

GUARANTEE

This machine is guaranteed by IMC for 1 Year from the date of purchase from IMC or from one of its stockists, dealers or distributors.

The guarantee is limited to the replacement of faulty parts or products and excludes any consequential loss or expense incurred by purchasers. Defects which arise from faulty installation, inadequate maintenance, incorrect use, connection to the wrong electricity supply or fair wear and tear are not covered by the guarantee.

Please observe these instructions carefully

This guarantee applies in this form to installations within the UK only.

WASTE OUTLET CONNECTION

All 700 & 800 Series Disposers have a 2+BSP female threaded outlet which is designed to be connected to 54mm copper or plastic piping. The size of the waste outlet must not be reduced. A running trap should be fitted although ~~P~~ or ~~S~~ type traps can be used. Do not fit a bottle trap. The length of run between the machine and the main junction must be kept to a minimum and the pipe must have a positive fall of at least 1 in 7. Changes of direction should be made with swept bends rather than elbows, and cleaning eyes should be fitted where possible, in accordance with standard plumbing practice.

The waste outlet position can be rotated at 90° intervals by unbolting the waste outlet casting from the hopper flange plate. Rotate the motor and waste outlet casting to the required orientation. Check that the gasket between the waste outlet casting and the flange plate is in place. Refit the nuts and bolts and tighten uniformly all round. Do not over tighten, but ensure that the gasket is nipped firmly and the hopper is rigidly fixed without any distortion of its bottom flange.

All Waste Disposers must have an independent drain pipe that does not also serve sinks, dishwashers or similar equipment. The end of the waste pipe must be beyond any grease traps and if the outlet feeds into an outside gully, the pipe should enter the gully below the covering grid. Use a back entry yard gully.

When fitting the trap make certain that the top invert of the trap lies below the waste outlet of the waste disposer. Failure to do this will prevent the machine from draining completely.

WATER SUPPLY CONNECTION

A cold water supply with a minimum head of 0.2 to 10 bar is required. This is connected to the units at the water control valve using a 15mm compression joint, supplied with the machine. A stopcock should be fitted to the water supply.

The rate of water flow for the disposal of normal food waste is 14-18 litres per minute for 700 Series machines and 18-27 litres per minute for 800 series machines. Adjust the water supply control valve to achieve the desired flow rate.

ELECTRICAL CONNECTION

All electrical work must be carried out by a qualified electrician and in accordance with the IEE Codes of Practice. Examine the rating plate attached to the motor to ensure that the characteristics shown are correct for the supply available. The cables fitted to the controller are the minimum required for individual connection to the mains supply. Site conditions may vary with additional length of cable run, encapsulation in trunking, bunched with other cables etc. Should this apply, the electrician must alter the cable accordingly.

All machines are supplied with a starter with forward, reverse and stop buttons. The starter also controls the water flow. This unit must be connected to the mains supply using the starter provided. Omission of the starter eliminates overload protection for the motor and will invalidate the guarantee.

The 700/800 Series Disposers should be connected to a 30A isolator providing at least 3mm separation in all poles. The table below illustrates typical fuse ratings for an ambient temperature of 25 to 35°C. Should the environment temperature be greater than this, derate accordingly.

Unit	Voltage	Full Load Current	Fuse Rating per Phase
700	400-3-50	2.8 Amps	5 Amps
	440-3-60	2.6 Amps	5 Amps
	230-1-50	7.4 Amps	15 Amps
800	400-3-50	5.3 Amps	15 Amps
	440-3-60	5.1 Amps	5 Amps

The supply to the machine must also be protected by a 30mA RCD.

Warning: This appliance must be earthed.

If the supply cord becomes damaged it must be replaced by qualified electrician in order to avoid a hazard.

RELEASING A JAM

Food Waste Disposers can jam under overload or if unsuitable materials are placed inside. IMC machines are designed to withstand this and no damage will normally result as the machine will switch itself off. It is necessary to clear the jam as follows:

723 Disposer

1. Switch off at the mains isolating switch.
2. Take out any bulk waste in the baffle chamber. Rubber gloves are recommended
3. Lower the release wrench through the aperture in the baffles and locate between the hexagonal boss on the centre of the rotor and the vane of the rotor. Exert pressure in both directions until the jammed material releases.
4. Remove the release wrench
5. Switch on at the mains isolating switch.
6. Press the START button and continue disposal.

725, 726 and 800 Series Disposers

1. Switch off at the mains isolating switch.
2. Remove the baffle by unscrewing the interlock knob and lifting off.
3. Take out any bulk waste in the disposal chamber. Rubber gloves are recommended. If the item which blocked the disposer is apparent, remove it.
4. Place the hexagon socket of the release wrench over the central hexagonal boss on the rotor and lever backwards and forwards until the jammed material releases. Remove the release wrench and pull out the material.
5. Replace the wrench and ensure that the rotor is totally free throughout its full rotation. Remove the release wrench.
6. Replace the baffle, screwing the interlock knob fully home.
7. Switch on at the mains isolating switch.
8. Press the START button and continue disposal.

FAULT DIAGNOSIS**Machine does not start**

Cause	Action
Electrical supply is not turned on.	Switch on supply.
The fuses have blown or the circuit breaker has tripped.	Call site electrician to change fuse or reset circuit breaker. If problem persists contact service personnel.
Baffle is not correctly fitted.	Check baffle is secured. If problem persists contact service personnel.

Unexpected system stop

Cause	Action
Electrical supply turned off.	Switch on supply.
The fuses have blown or the circuit breaker has tripped.	Call site electrician to change fuse or reset circuit breaker. If problem persists contact service personnel.
Baffle is not correctly fitted.	Check baffle is secured. If problem persists contact service personnel.
Waste jammed in disposer grinding unit.	Remove blockage from grinding unit. See instructions on page 3.
Motor overload has tripped.	Allow motor to cool for 10 minutes and restart. If problem persists contact service personnel.

Waste not processed

Cause	Action
A blockage has occurred in the waste pipe.	Clear blockage from waste pipe

MAINTENANCE

12 Monthly, All models

Check for bearing wear by the sound of motor and side to side movement of rotor.

WARNING – BEFORE ATTEMPTING SERVICE WORK ENSURE THAT ELECTRICITY AND WATER SUPPLIES ARE TURNED OFF AT THE MAIN SUPPLY AND STOP COCK

ORDERING SPARE PARTS:

In the event that spare parts or accessories need to be ordered, please always quote the SERIES AND SERIAL NUMBER of the machine. This is to be found on the rating plate located near the supply cable.

For installations outside the UK please contact your supplier.

For information on IMC spares and service support (if applicable), please call IMC on +44 (0)1978 661155. Alternatively, contact us via email or fax:

IMC Service Desk

Fax: +44 (0)1978 667766

E-mail: service@imco.co.uk

IMC Spares Desk

Fax: +44 (0)1978 667759

E-mail: spares@imco.co.uk

MATERIAL CONTENT

The 700/800 Series disposers contain the following material:

Metals	Stainless steel, mild steel, brass and copper.
Plastics and rubber	Neoprene rubber. ABS and nylon
Other	Electrical components

WIRING DIAGRAMS

Figure 1 - Wiring Diagram, Single Phase

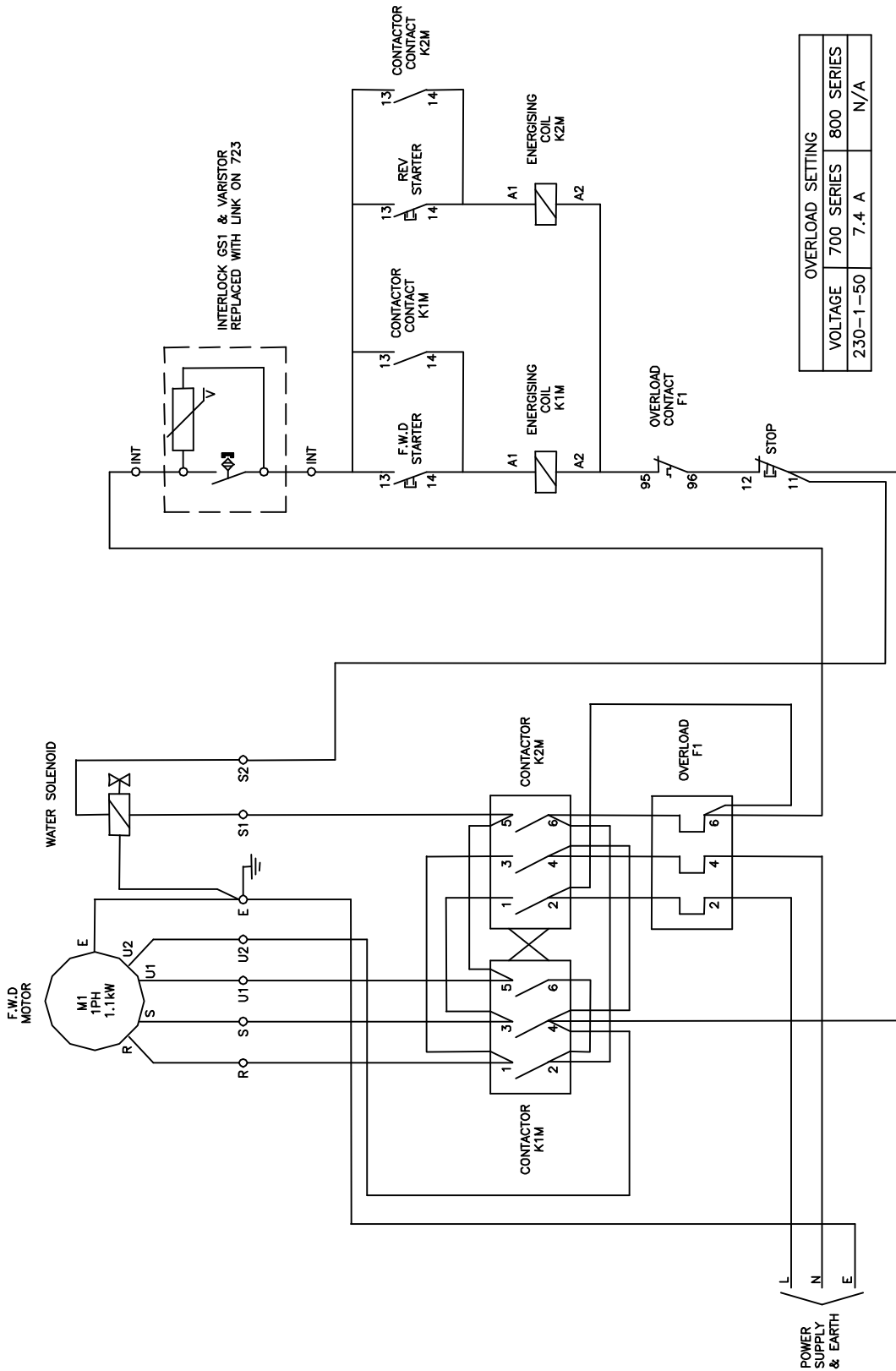
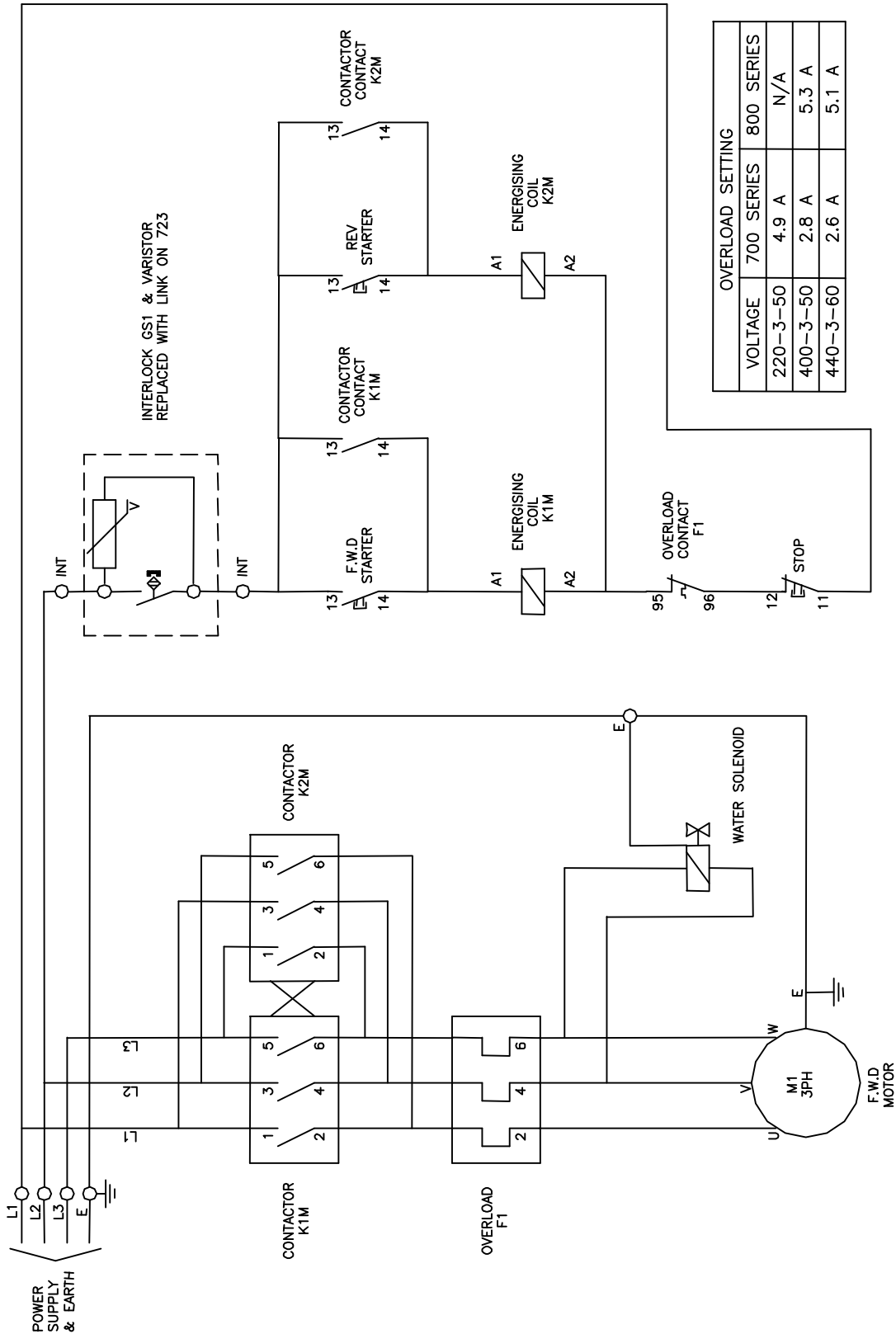

Figure 2 - Wiring Diagram, 3 Phase 4 Wire



OVERLOAD SETTING			
VOLTAGE	700 SERIES	800 SERIES	
220-3-50	4.9 A	N/A	
400-3-50	2.8 A	5.3 A	
440-3-60	2.6 A	5.1 A	

Figure 3 - Wiring Diagram, 3 Phase 5 Wire

Note: 723 Disposer is not available as a 5 wire machine.

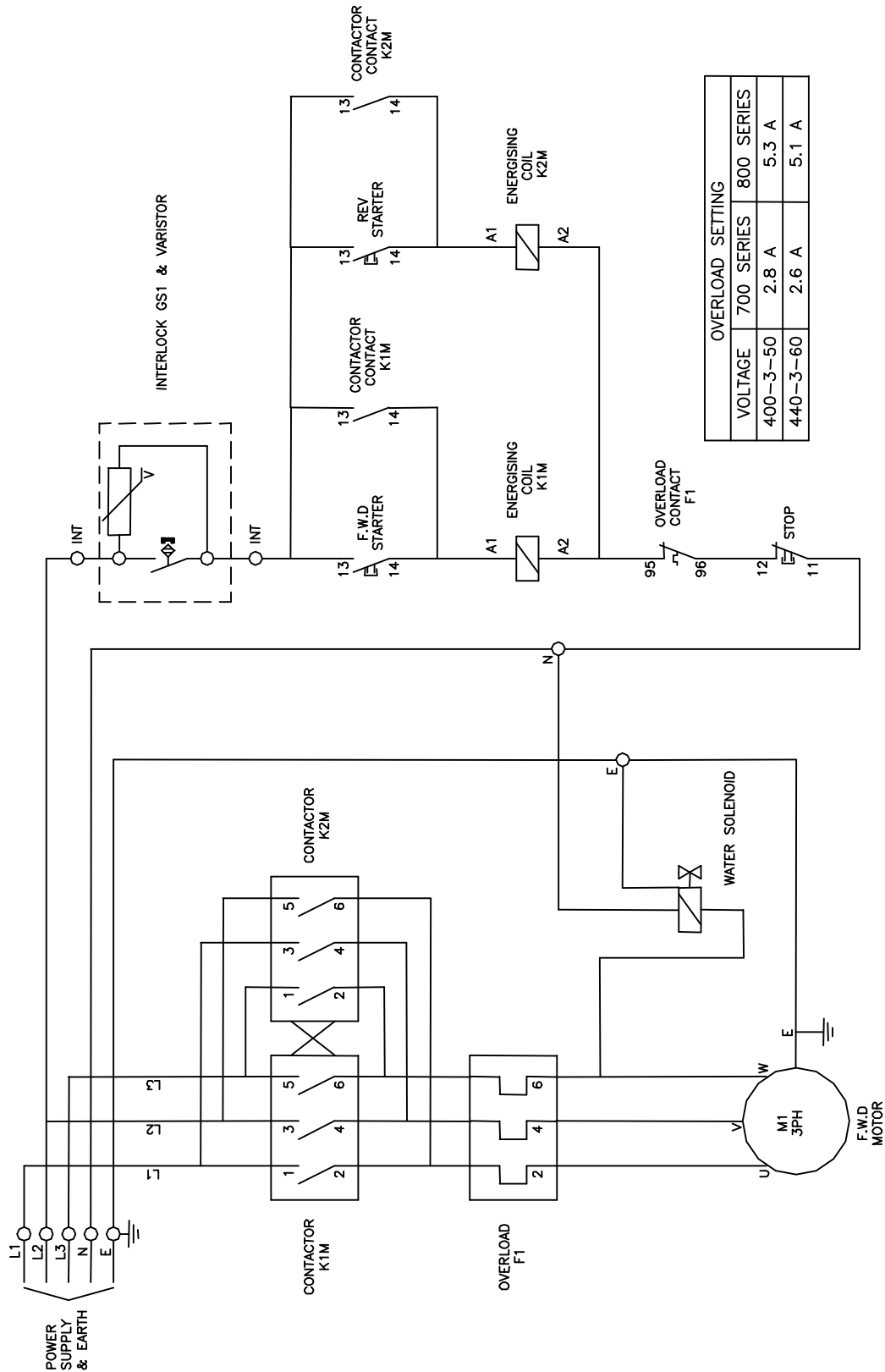

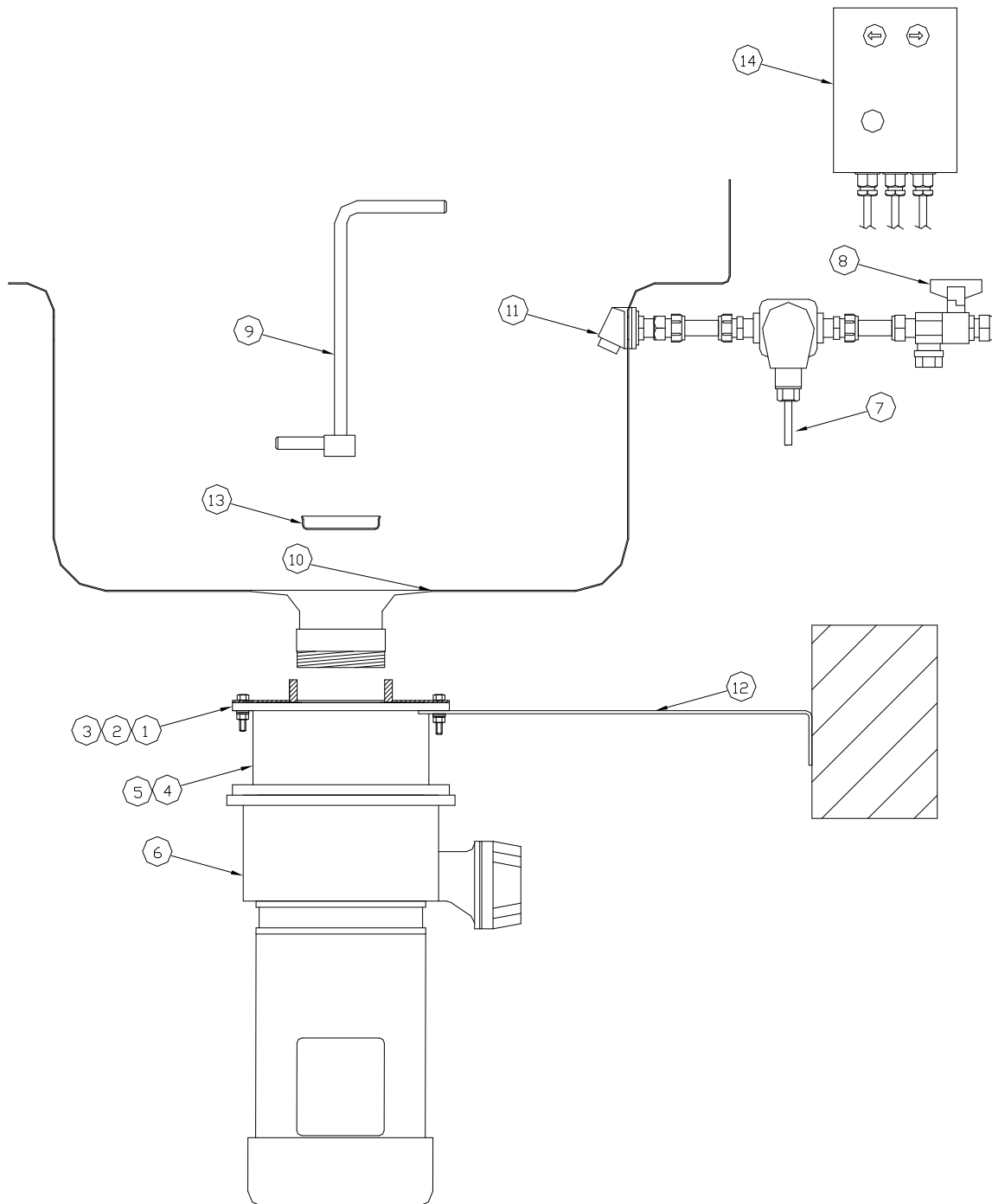
**PARTS ILLUSTRATION,
723****Note**

Item 10, 3 inch BSP externally threaded sink inlet assembly, is to be welded into the sink aperture prior to installation of the machine.

725, 726, 800 Series and Dump Station

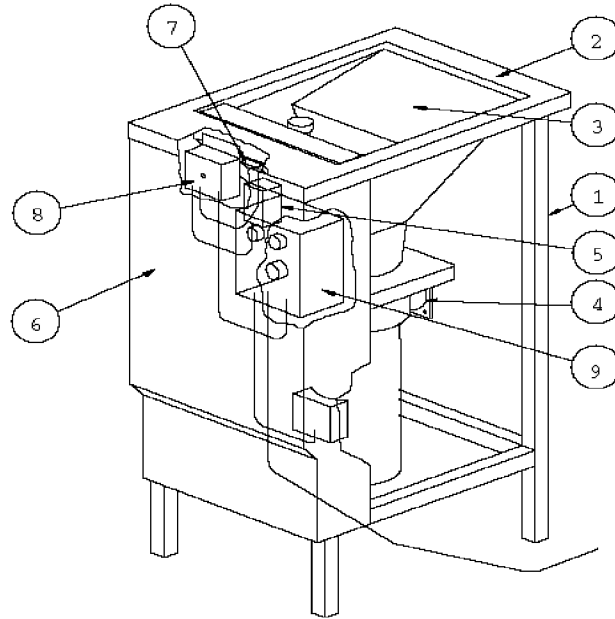
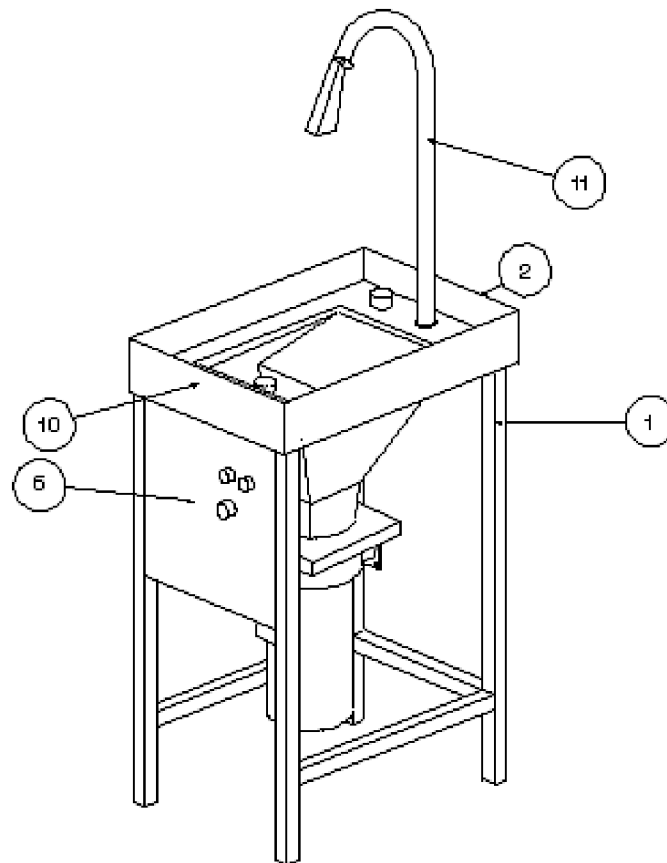
700 SERIES FOOD WASTE
DISPOSER

PARTS LIST**723**

Item	Part No	Description	Item	Part No	Description
1	E60/021	Flange Plate Assembly	8	J03/134	Ball valve / Strainer
2	A11/250	Gasket	9	S60/016	Release Key
3	D25/008	Washer M6	10	E60/019	Sink Inlet Assembly
	D25/005	Washer M6 Shakeproof			
	D20/013	Full Nut M6	11	J04/319	Trough Inlet
	D19/115	Screw M6			
			12	E60/022	Torque Bar
4	C60/001M1	Interface Casting			
5	E60/016	Baffle Welded Assembly	13	E10/019	Silver Saver (Optional)
			14	G30/353	Starter Box 230-1-50
6	G40157	Motor 1.1kW 230-1-50		G30/350	Starter Box 400-3-50 4 Wire
	G40/227	Motor 1.1kW 400-3-50			
	C23/010M1	Top Housing			
	D20/039	M10 Philidas Nut			
	D19/091	M10 x 30 Hex Head Screw			
	D25/010	M10 Plain Washer			
	C23/011M	Rotor			
	A02/047	Speedi Sleeve			
	C13/005M1	Cutter ring			
	D19/044	M8 x 16 Hex Head Screw			
	D25/070	Nylon Washer			
	L32/067	Washer			
	D25/041	Fibre Washer			
	A02/048	Seal			
	E30/102	Rotor Flinger			
	E30/103	Flinger Baffle			
	L32/085	1PH Rotor Spacer (34mm)			
	L32/088	3PH Rotor Spacer (13mm)			
	A11/162	Motor Shield Gasket			
	A00/048	Bearing Bush 35X39X20mm			
	D23/023	Stud			
	D25/012	M8 Seloc Washer			
	D20/023	M8 Full Nut			
	L54/001	Dowell Pin			
	A11/145	Hopper gasket			
	A11/098	Waste Outlet Gasket			
	C23/004M1Z	Waste Outlet			
	D19/097	M6 x 30 Hex Head Screw			
7	S60/013	Solenoid 230V (1ph)			
	S60/006	Solenoid 400V (4 wire 3ph)			
	J04/073	Straight Coupler			

When ordering spare parts or accessories always quote the SERIES NUMBER of the machine, found on the rating label.

725 & 726 Series.

Item	Part No	Description	Item	Part No	Description
1	E60/001	Frame . 726	5	S60/004	Solenoid 230V (1ph & 5 wire 3ph)
	A19/010	Adjustable Foot		S60/003	Solenoid 400V (4 wire 3ph)
	A13/054	Square Foot		J04/073	Straight Coupler
				J01/080	Copper Pipe
2	E60/003	Hopper - 725		J03/134	Ball valve / Strainer
	E60/009	Hopper & Top - 726		J04/130	Elbow
	D19/031	M5 x 10 Hex Head Screw			
	D25/021	M5 Plain Washer	6	E68/007	Front Panel . 726
	D25/004	M5 Shakeproof Washer		D19/031	M5 x 10 Hex Head Screw
				D25/021	M5 Plain Washer
3	E60/004	Baffle		D25/004	M5 Shakeproof Washer
	A31/002	Magnet			
	D21/043	M5 x 10 Pan Head Screw	7	G45/053	Switch Interlock
	D25/004	M5 Shakeproof Washer		D21/047	M5 x 25 Pan Head Screw
	M68	Interlock Body		D25/004	M5 Shakeproof Washer
	M69	Interlock Knob			
	M48	Interlock Plug	8	G76/021	Terminal Box
	D26/017	Pin		D21/101	M4 x 10 Pan Head Screw
4	G40157	Motor 1.1kW 230-1-50	9	G30/353	Starter Box 230-1-50
	G40/227	Motor 1.1kW 400-3-50		G30/350	Starter Box 400-3-50 4 Wire
	G40/232	Motor 1.1kW 400-3-60		G30/351	Starter Box 400-3-50 5 Wire
	C23/010M1	Top Housing		E60/007	Back Plate . 726
	D20/039	M10 Philidas Nut		A10/134	Blind Grommet
	D19/091	M10 x 30 Hex Head Screw		A11/177	Sponge Washer . 726
	D25/010	M10 Plain Washer		G30/350	Starter Box 400-3-50 4 Wire
	C23/011M	Rotor			
	A02/047	Speedi Sleeve	10	E30/035 Z	Release Key
	C13/005M1	Cutter ring			
	D19/044	M8 x 16 Hex Head Screw	OPTIONAL ITEMS		
	D25/070	Nylon Washer			
	L32/067	Washer		E60/010	Side panel - 726
	D25/041	Fibre Washer			
	A02/048	Seal			
	E30/102	Rotor Flinger			
	E30/103	Flinger Baffle			
	L32/085	1PH Rotor Spacer (34mm)			
	L32/088	3PH Rotor Spacer (13mm)			
	A11/162	Motor Shield Gasket			
	A00/048	Bearing			
	D23/023	Stud			
	D25/012	M8 Seloc Washer			
	D20/023	M8 Full Nut			
	L54/001	Dowell Pin			
	A11/145	Hopper gasket			
	A11/098	Waste Outlet Gasket			
	C23/004M1Z	Waste Outlet			
	D19/097	M6 x 30 Hex Head Screw			

When ordering spare parts or accessories always quote the SERIES NUMBER of the machine, found on the rating label.

800 Series and Dump Station.

Item	Part No	Description	Item	Part No	Description
1	E68/008	Frame . 826	5	S60/004	Solenoid 230V (5 wire 3ph)
	E68/005	Frame . Dump Station		S60/003	Solenoid 400V (4 wire 3ph)
	A10/481	Adjustable Foot		J04/073	Straight Coupler
				J01/044	Copper Pipe
2	E68/001	Hopper - 825		J03/134	Ball valve / Strainer
	E68/010	Hopper & Top - 826		J04/130	Elbow
	E68/009	Hopper & Top . Dump Station			
	D19/031	M5 x 10 Hex Head Screw	6	E68/007	Front Panel . 826
	D25/021	M5 Plain Washer		E68/006	Front Panel . Dump Station
	D25/004	M5 Shakeproof Washer		D19/031	M5 x 10 Hex Head Screw
				D25/021	M5 Plain Washer
3	E68/002	Baffle		D25/004	M5 Shakeproof Washer
	A31/002	Magnet			
	D21/043	M5 x 10 Pan Head Screw	7	G45/053	Switch Interlock
	D25/004	M5 Shakeproof Washer		D21/047	M5 x 25 Pan Head Screw
	M68	Interlock Body		D25/004	M5 Shakeproof Washer
	M69	Interlock Knob			
	M48	Interlock Plug	8	G76/021	Terminal Box
	D26/017	Pin		D21/101	M4 x 10 Pan Head Screw
4	G40/122	Motor 2.2kW 400-3-50	9	G30/323	Starter Box 400-3-50 4 Wire
	A10/266	Cable Gland		G30/354	Starter Box 400-3-50 5 Wire
	C54/001M2	Housing		E60/007	Back Plate . 826 & Dump Station
	D23/024	Stud		A10/134	Blind Grommet
	D20/030	M16 Half Nut		A11/177	Sponge Washer . 826 & Dump Station
	C24/004M2	Rotor			
	C15/013M1	Cutter ring	10	E68/012	Fascia Panel . Dump Station
	D19/109	M16 x 25 Hex Head Screw		D19/031	Screw . Dump Station
	D19/050	M10 x 20 Hex Head Screw		D25/004	Shakeproof Washer . Dump Station
	D25/023	Nylon Washer			
	L32/018	Washer	11	F63/200	Pre Rinse PR2 . Dump Station
	D25/022	Fibre Washer			
	A02/060	Seal	OPTIONAL ITEM		
	A02/061	Speedi Sleeve			
	E30/020	Rotor Flinger		E68/013	Side Panel - 826
	L54/004Z	Seal Sleeve			
	A02/052	Seal			
	J06/028	Nylon Tube			
	D23/035	Stud			
	D25/011	M12 Plain Washer			
	D20/033	M12 Nyloc Nut			
	D26/007	Tension Pin			
	D22/046	M10 x 16 Socket Head Screw			
	A11/150	Hopper gasket			
	A11/098	Waste Outlet Gasket			
	C23/004M1Z	Waste Outlet			

When ordering spare parts or accessories always quote the SERIES NUMBER of the machine, found on the rating label.